

NOTES:

1. 100mm diameter mains shall have 32mm diameter tapped holes.
2. All larger mains shall have 50mm diameter tapped holes.
3. Tapping bands shall be a minimum of 500mm apart from each other as per AS/NZS 2032 Clause 4.7.

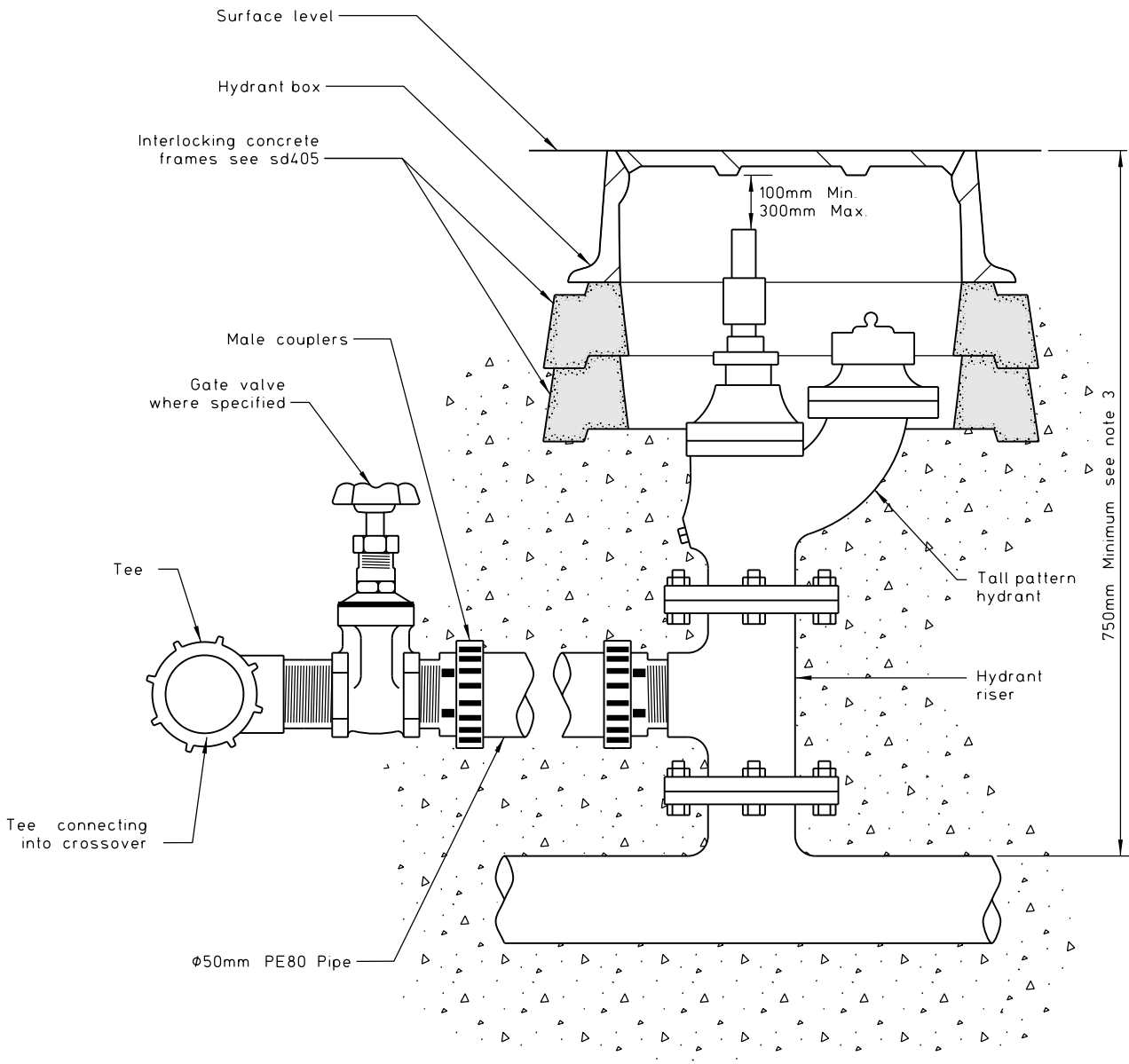

NOTES:

1. All backfill in accordance with CSS Part 1.
2. Gate valve shall be located outside hydrant frame.
3. Cover may require increasing to install tall hydrants.
4. Gate valve not required for greenfield developments.

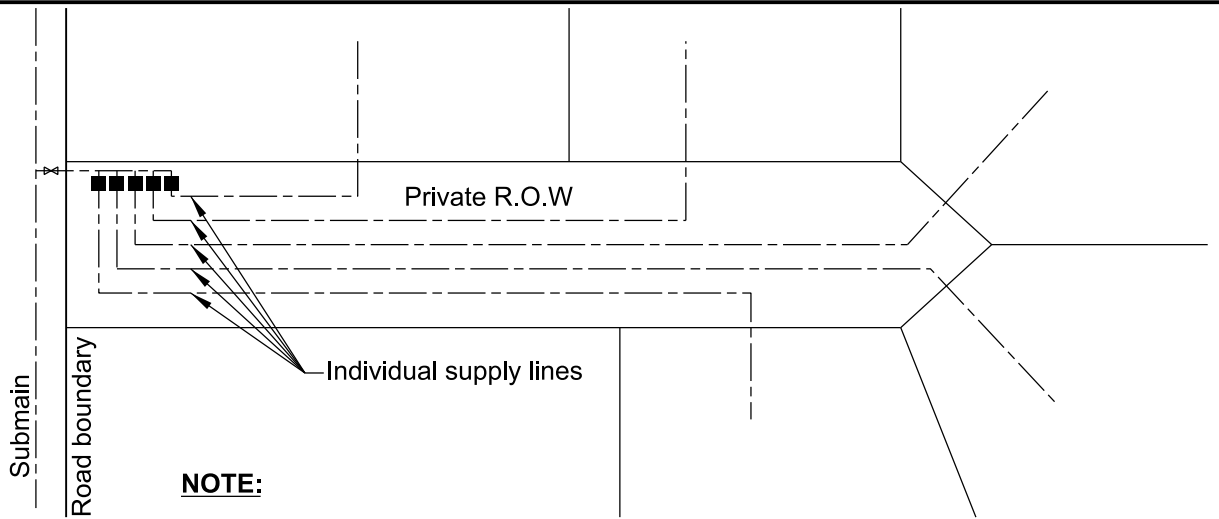

NOTE:

1. Where there are up to 4 connections off the right of way the connections are to be installed within legal road at the road boundary.

COMMON LAND CONNECTION POSITION

Not to Scale

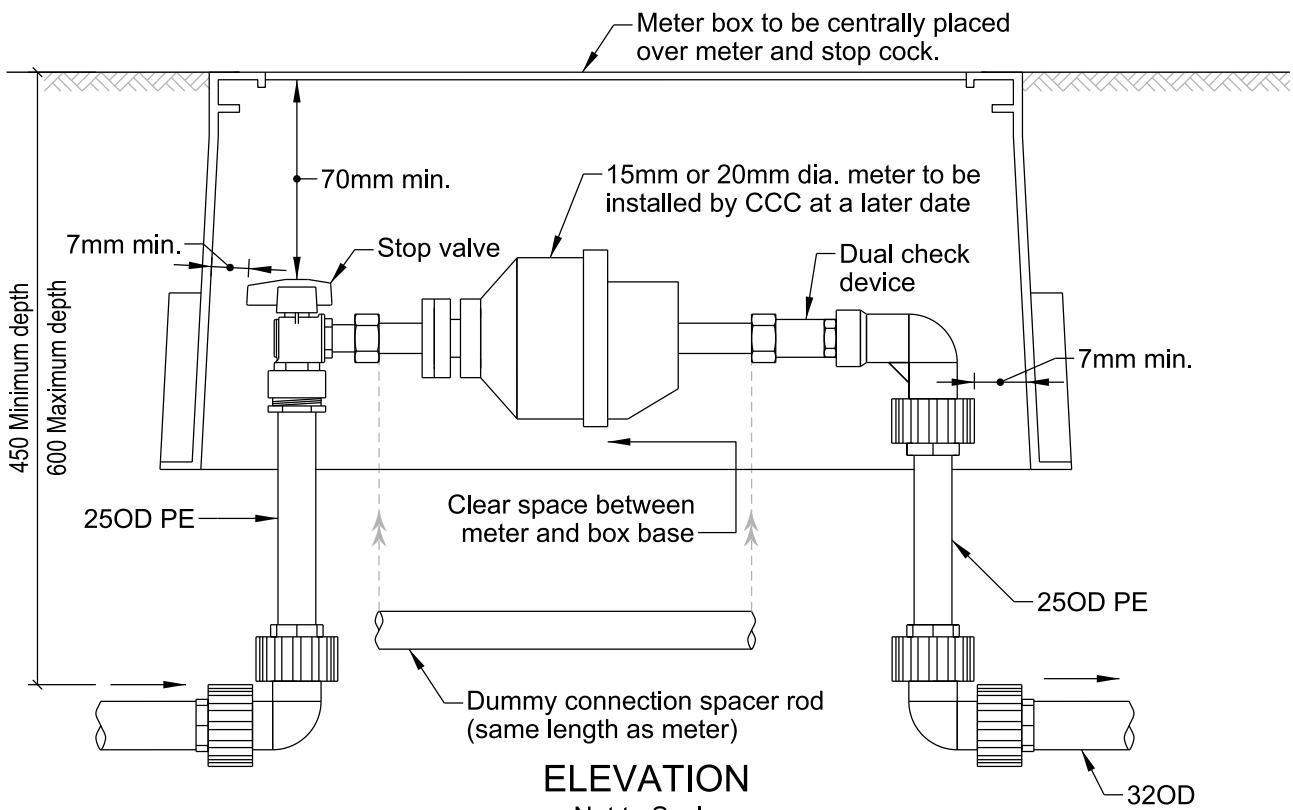

ELEVATION

Not to Scale

NOTES:

1. Connection box to be heavy duty for commercial installation and trafficable where ROW serves over 8 lots.
2. Connection to be 15 or 20mm as specified.
3. Backfill to be in accordance with CSS: Part 1.
4. 'Point of Supply' is at the road boundary.
5. Install 'Restricted Connection' sheet 2 where specified.
6. Connection box to be placed on precast concrete frames where located in driveways.

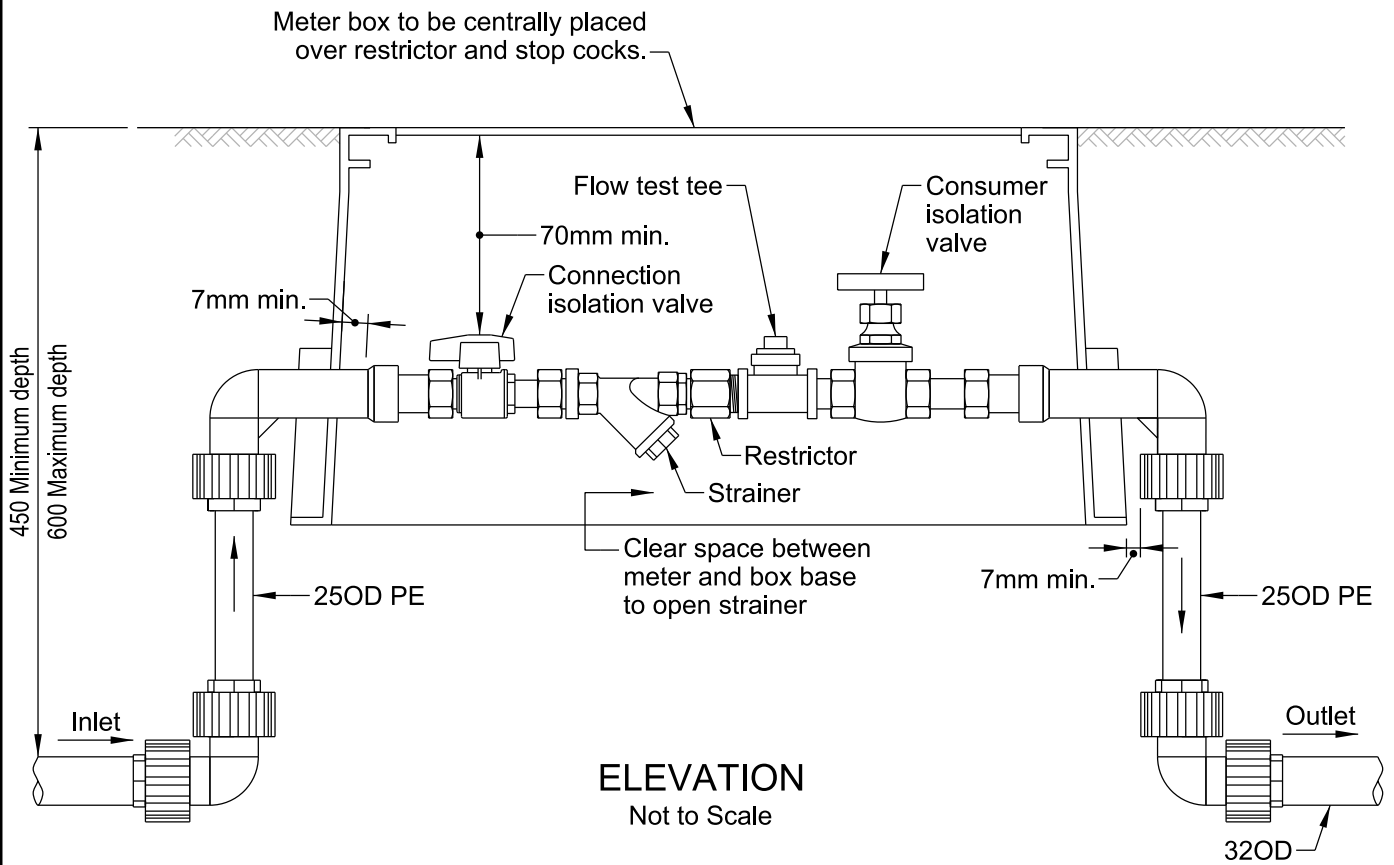

ELEVATION
Not to Scale

NOTES:

1. Gate and stop valves to be operational without removing any fittings.
2. Connection to be 15mm.
3. Backfill to be in accordance with CSS: Part 1.
4. 'Point of Supply' is at the road boundary.
5. Install 'Restricted Connection' in place of sheet 1 where specified.
6. Connection box to be placed on precast concrete frames where located in driveways.
7. Contractor shall confirm flow rate with Council prior to installation. Restrictor size and flow rate shall be included in as-built information provided to Council.



RESTRICTED CONNECTION



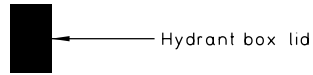

COVER MARKING



TRIANGLE MARKING
(Adjacent to centreline)

HYDRANT MARKINGS
Not to Scale



COVER MARKING

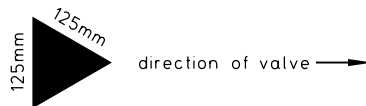

TRIANGLE MARKING
(On top of kerb)

SLUICE VALVE MARKINGS
Not to Scale

NOTES:

1. Hydrants to be marked with yellow approved roadmarking paint.
2. Sluice valves to be marked with white approved roadmarking paint.
3. Shut valves to be marked with red approved roadmarking paint.
4. Anti-clockwise opening butterfly valves to be marked with yellow approved roadmarking paint.

VALVE FRAME - (UPPER)

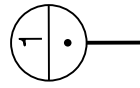
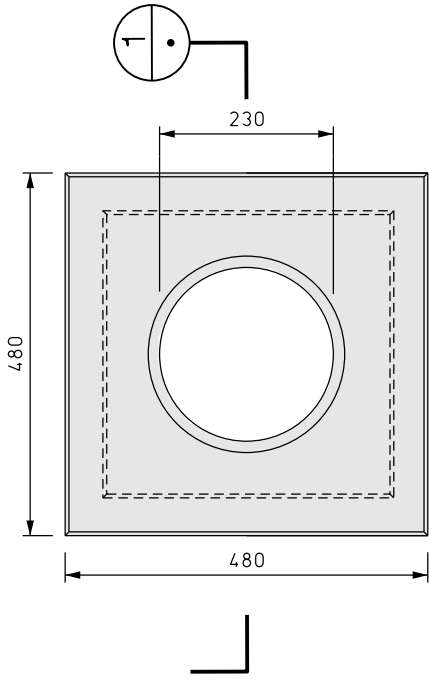

HYDRANT FRAME

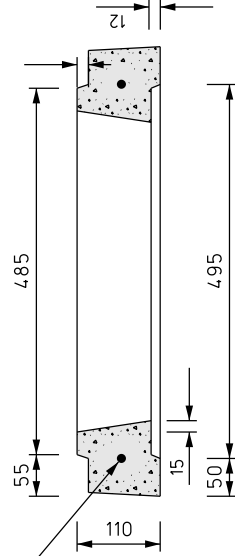
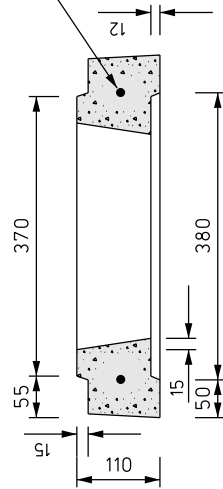
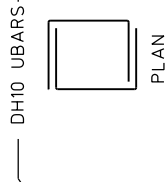
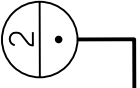
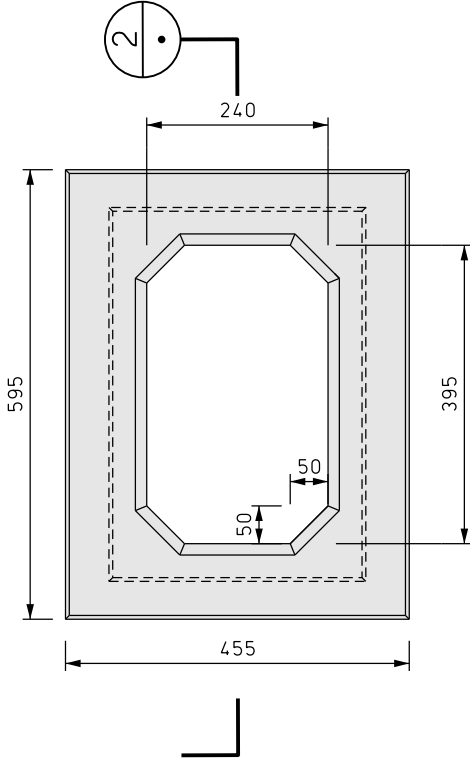

NOTES:

1. Reinforcing shall be placed 'centrally' in frame (at optimal cover)
2. Concrete shall be 30MPa at 28 days
3. Concrete finish shall be F4 or better.
4. Construction to comply with CSS Part 3, Clause 12.

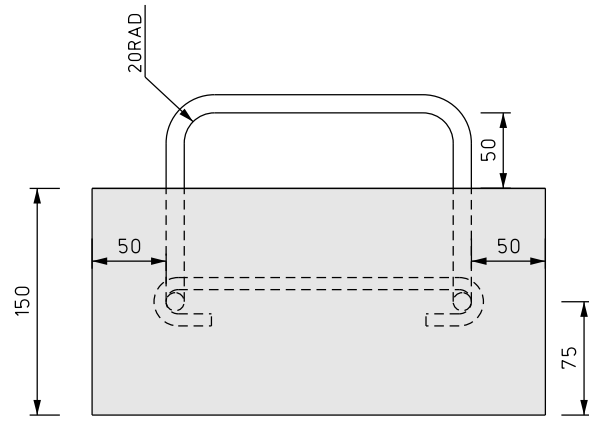

ELEVATION

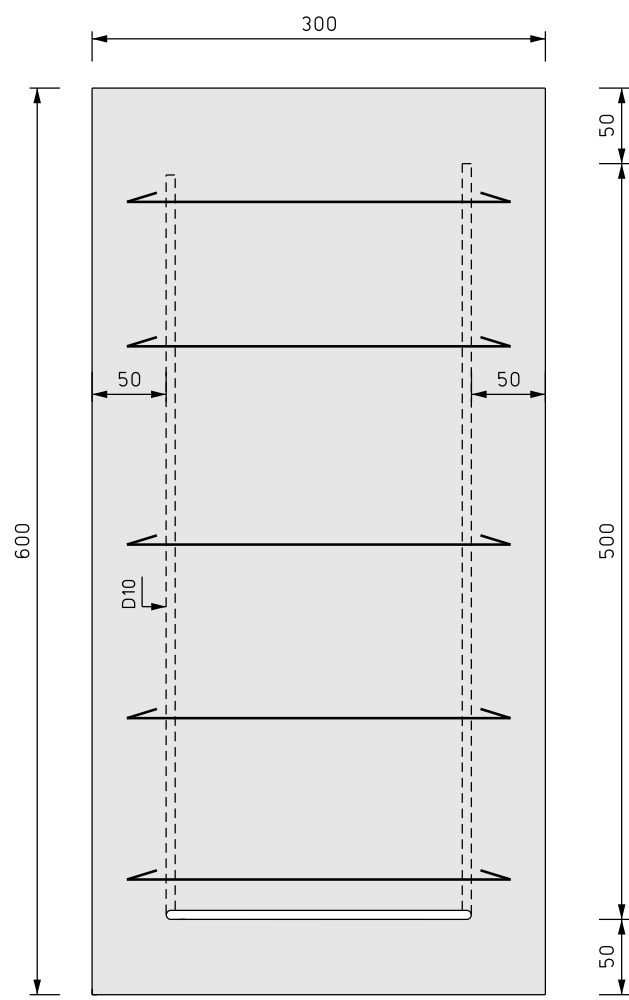

PLAN

NOTES:

- 1. Concrete shall be 30MPa at 28 days.
- 2. Construction to comply with CSS part 3 : clause 12.
- 3. Concrete finish shall be U3.

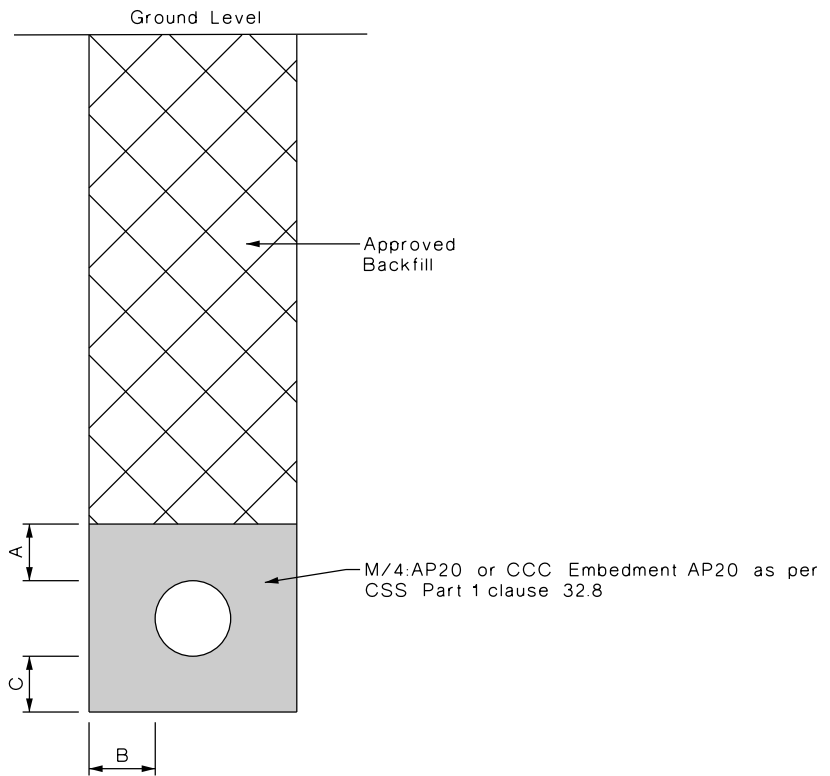

Nominal Pipe Diameter ϕ	A	B	C
< 150	100	100	100
≥ 150 < 300	150	150	100

Two H4 treated timber wedges where a precast thrust block is installed, one each installed from top and bottom.

Concrete thrust block to specified dimensions or to SD406.

Edge of excavation

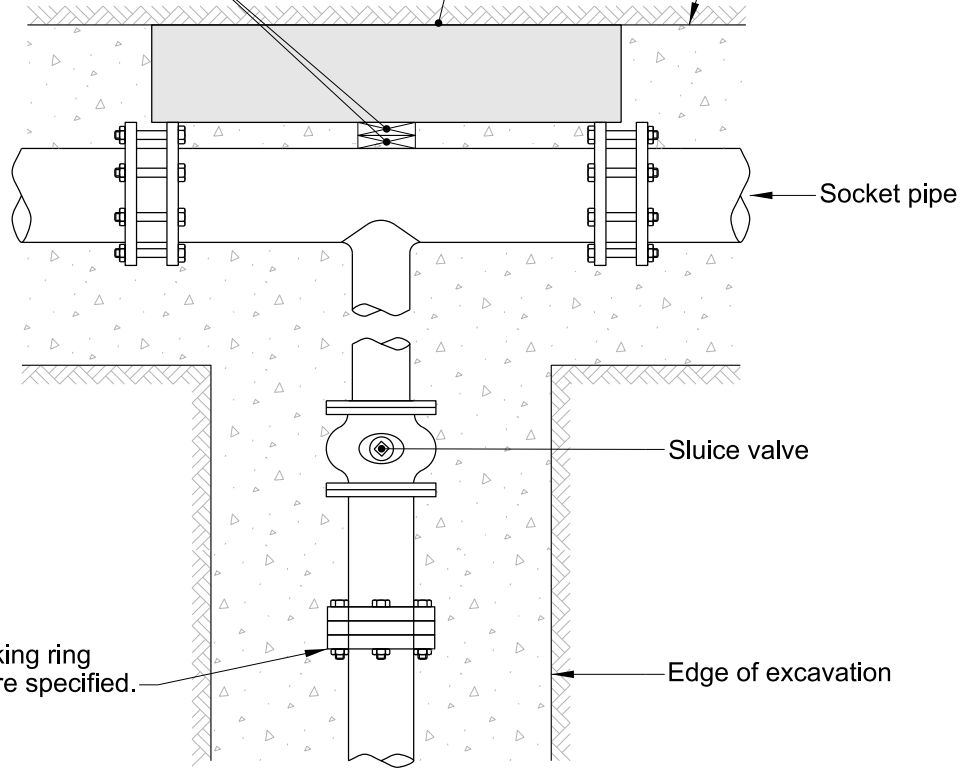

PLAN

NOTES:

- 1) Concrete to be 40MPa 150mm slump.
- 2) PVC and PE pipes adjacent to site poured concrete shall be wrapped with 6mm Denso tape or 250 micron polyethylene film or equivalent.

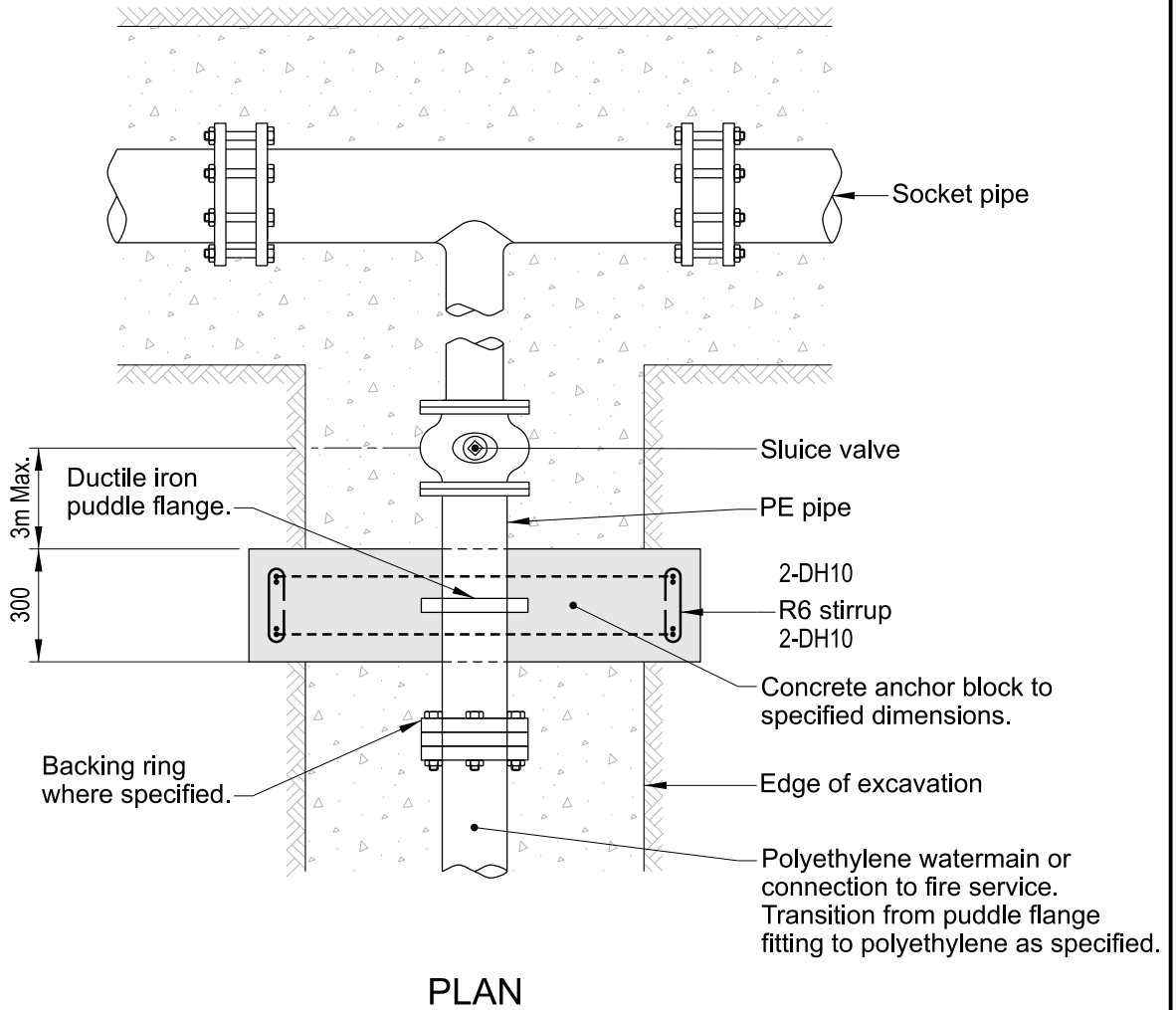

NOTES:

- 1) Concrete to be 40MPa 150mm slump.
- 2) PVC and PE pipes adjacent to site poured concrete shall be wrapped with 6mm Denso tape or 250 micron polyethylene film or equivalent.

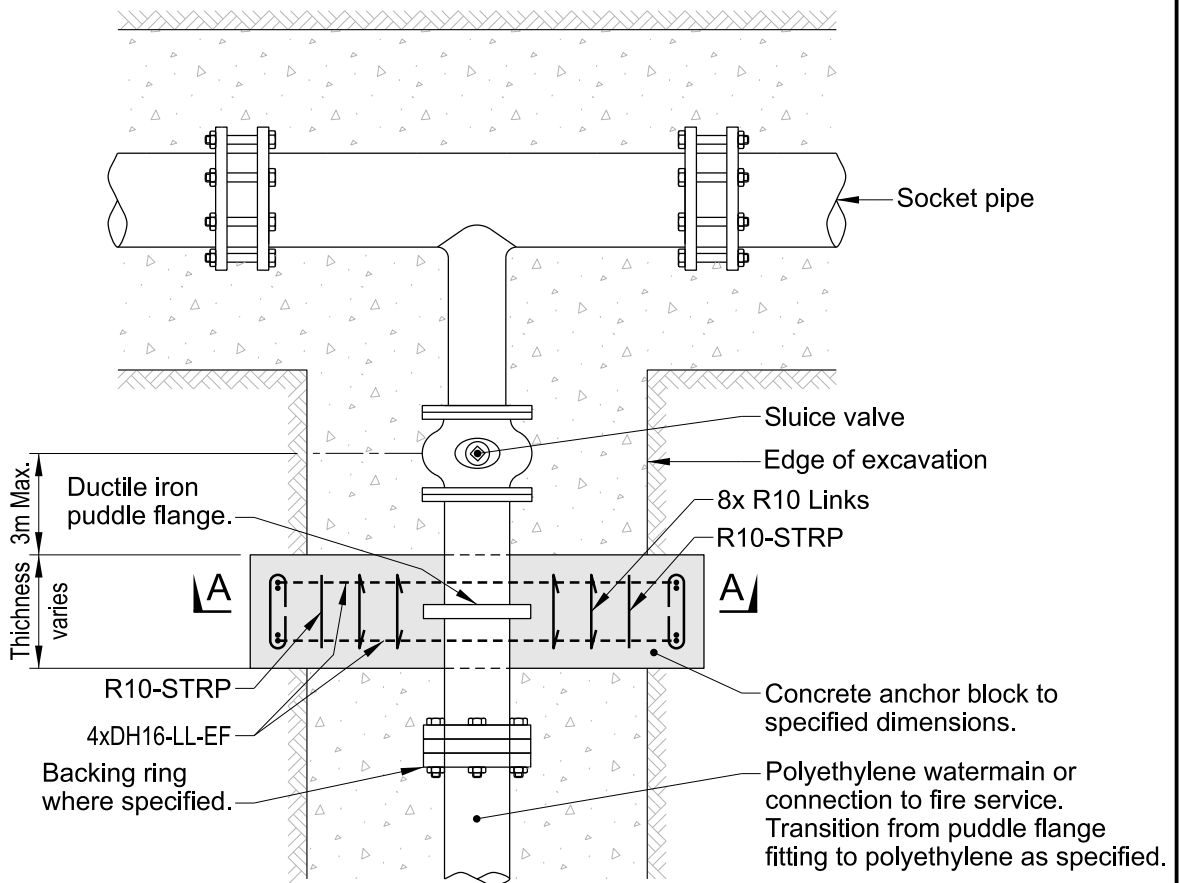

PLAN

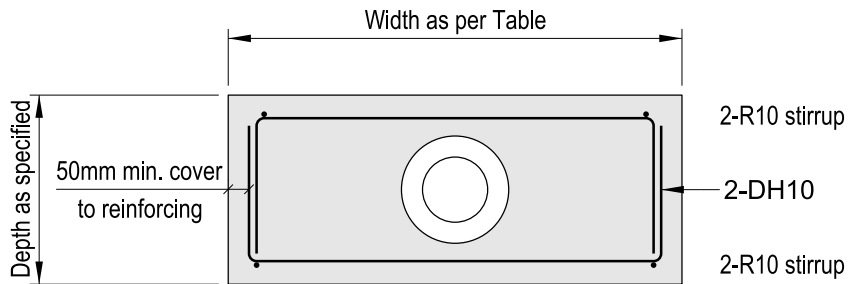

SECTION A-A

Table A: Inline Thrust Block Sizes				
Main Size	Width (mm)	Depth (mm)	Thickness (mm)	Stirrups
125OD	600	600	400	4xR10, Evenly spaced
180OD	700	600	500	4xR10, Evenly spaced
250OD	1000	700	500	6xR10, Evenly spaced
355OD	1000	800	600	6xR10, Evenly spaced

1) Rated for ground bearing capacity of 50kPa.
 2) Anchor Blocks are rated for test pressure of 1000kPa.
 3) For diameters greater than 355OD site specific design required.

NOTES:

- 1) Concrete to be 40MPa 150mm slump.
- 2) PVC pipes adjacent to site poured concrete shall be wrapped with 6mm Denso tape or 250 micron polyethylene film or equivalent.

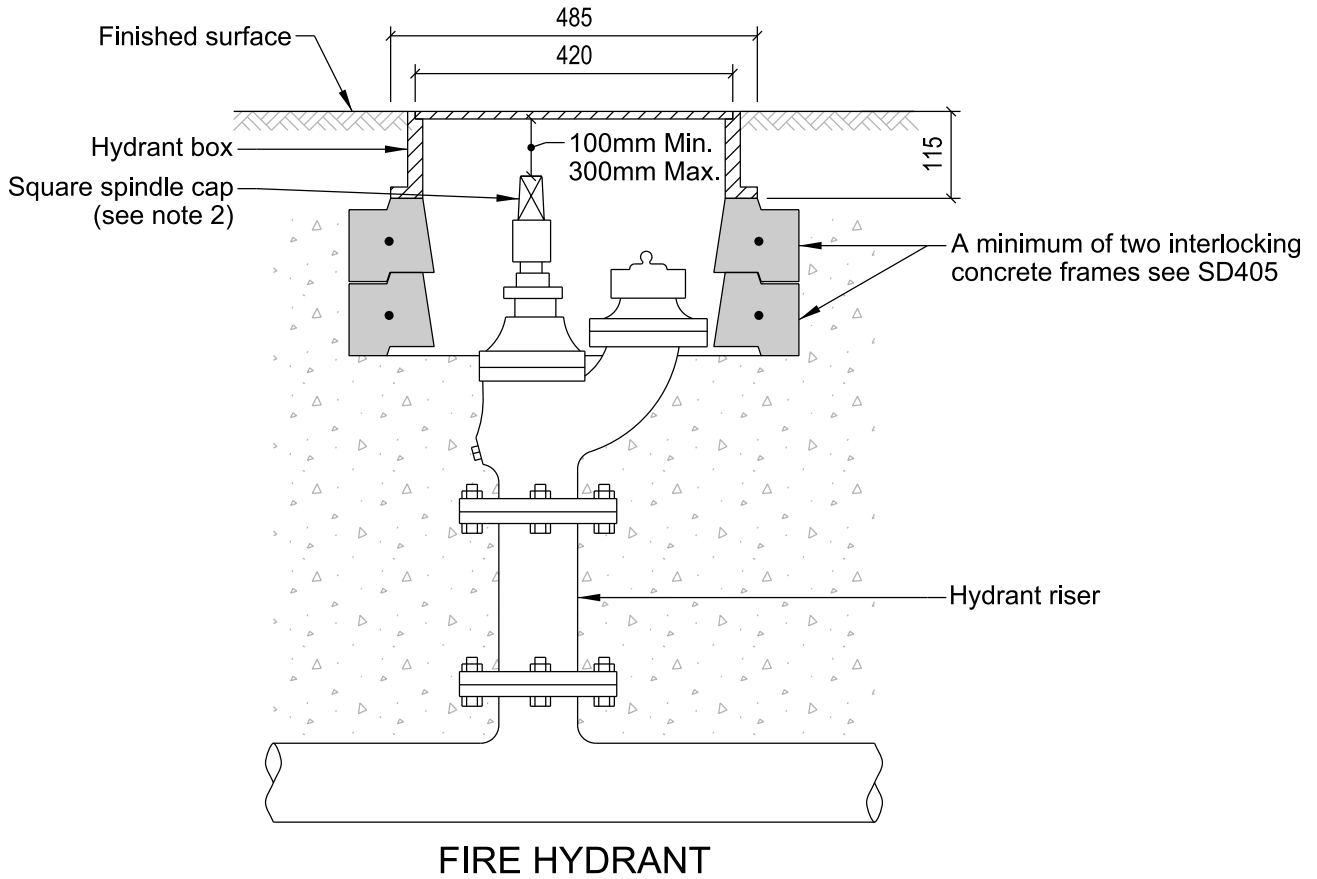

NOTE:

- 1) All backfill in accordance with CSS Part 1.

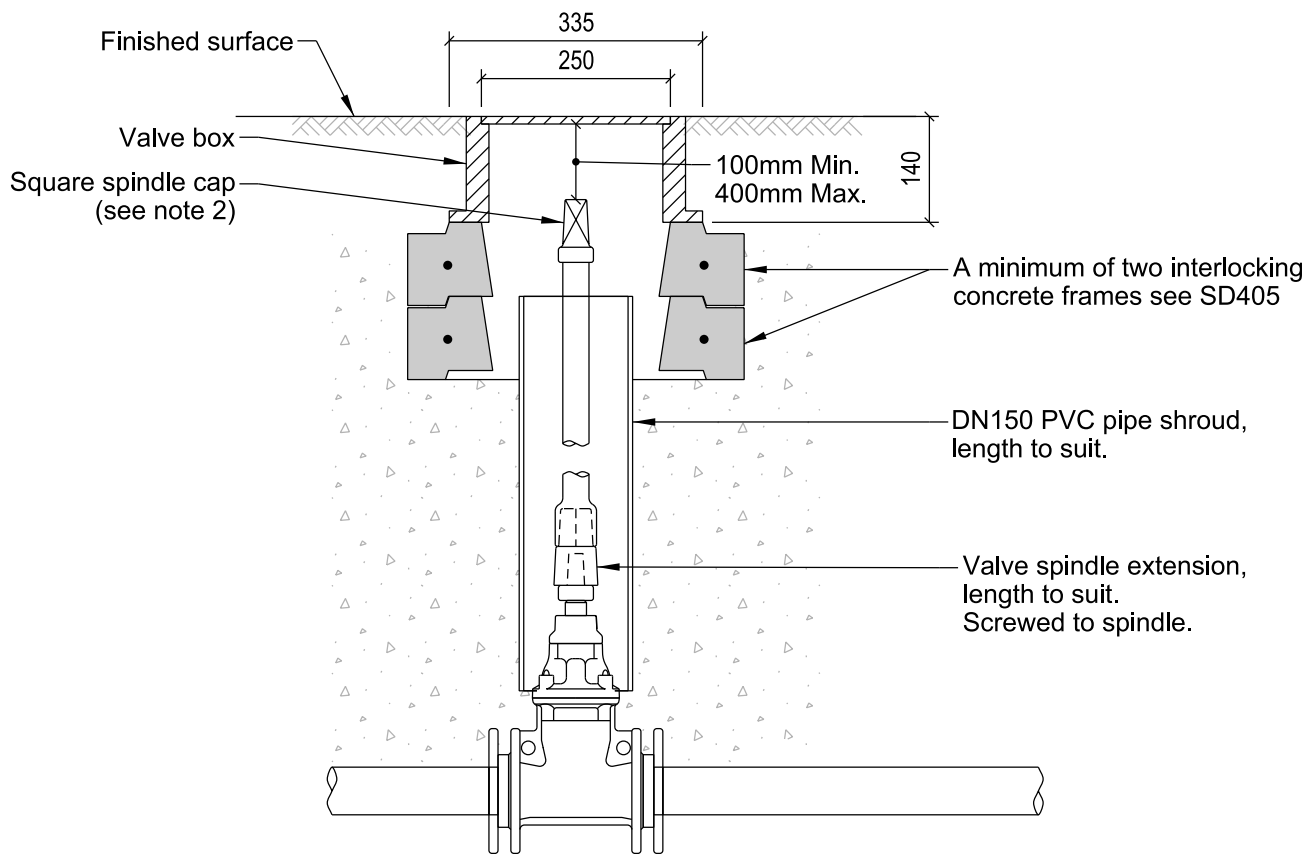

VALVE COVER FOR LOW TRAFFIC AREAS

NOTE:

1) All backfill in accordance with CSS Part 1.

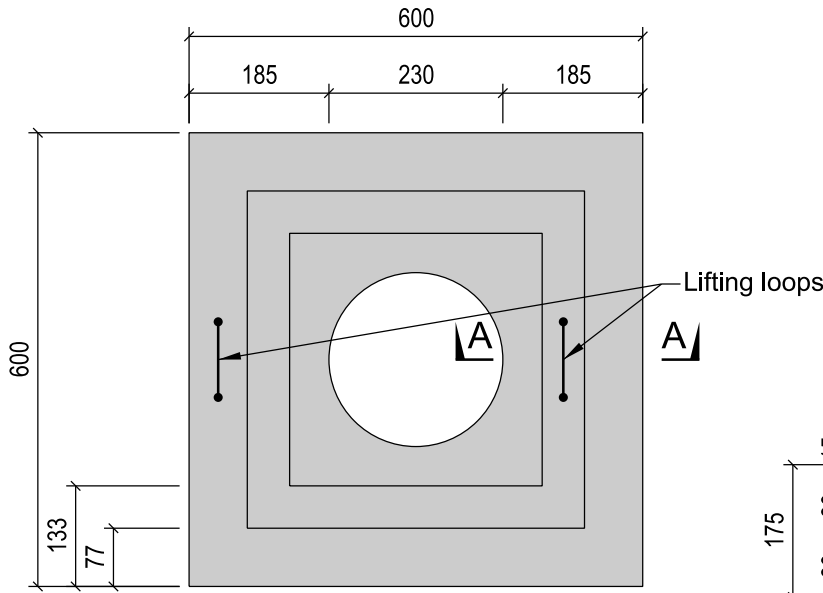

WIDE BASE FRAME
Unit weight = 94kg

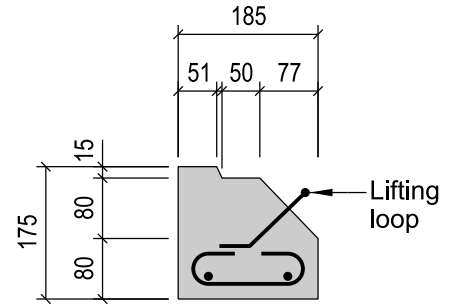

SECTION A-A

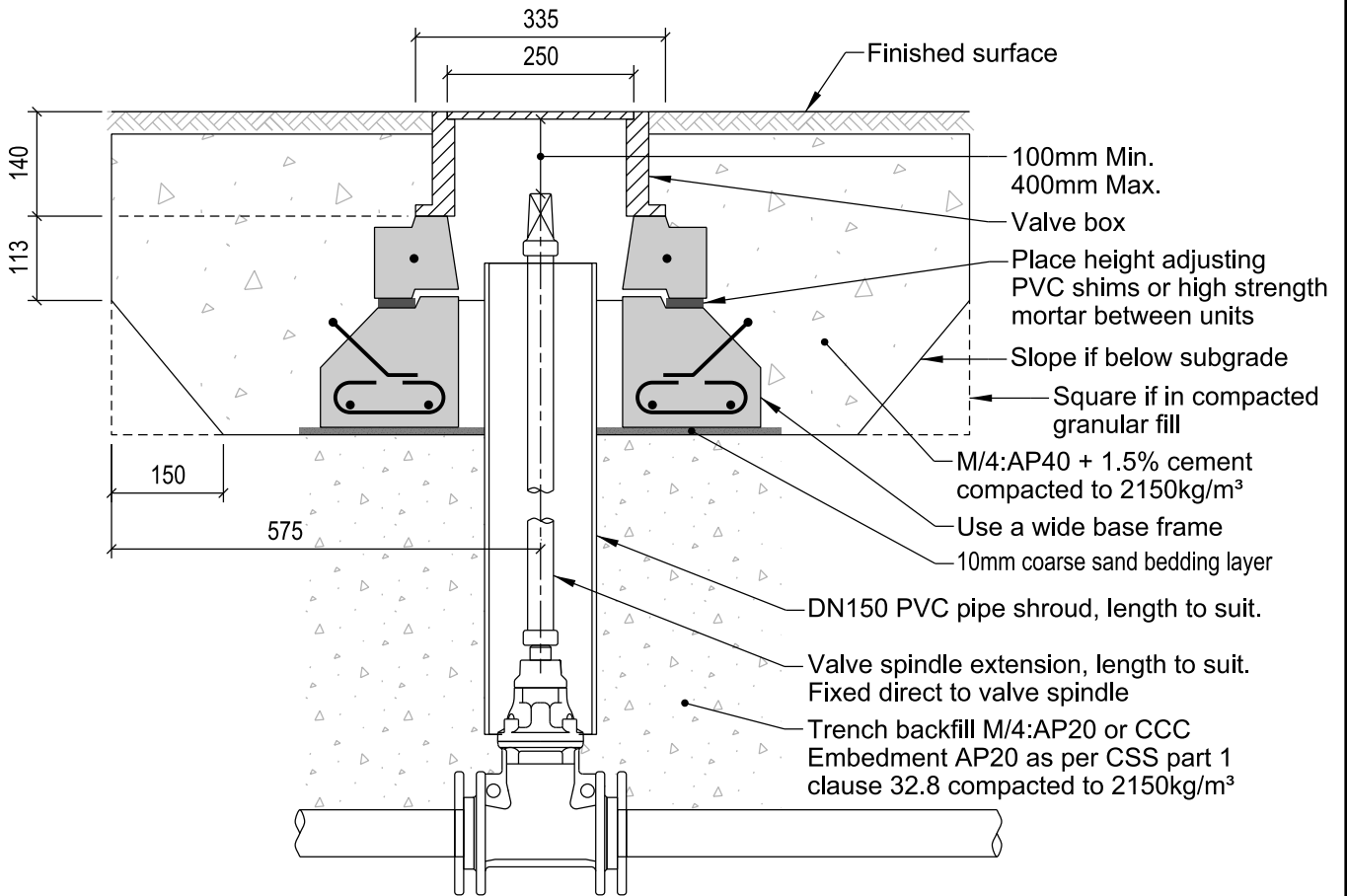

SECTION

NOTE:

1) All backfill in accordance with CSS Part 1.

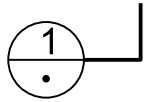
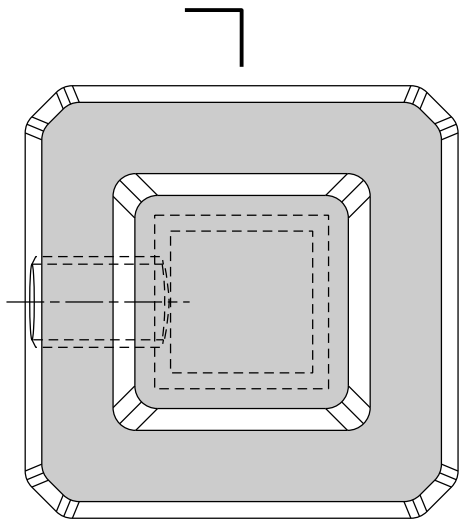

Top View

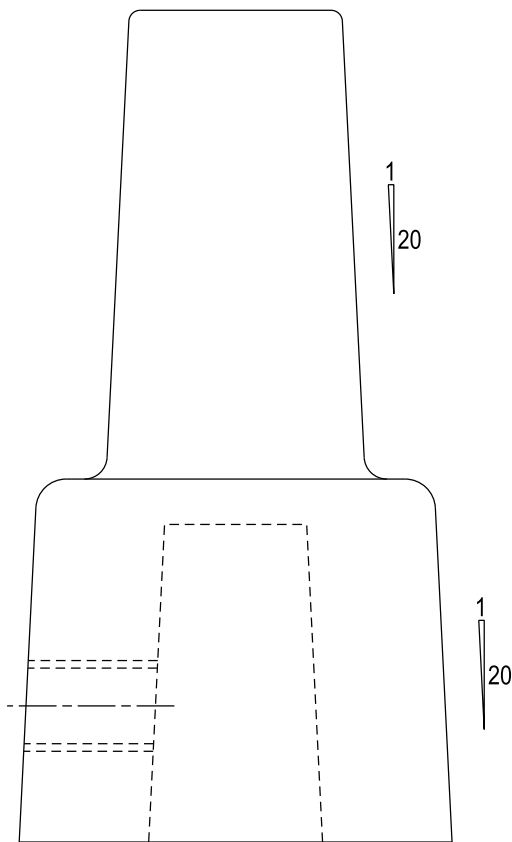

Side View

NOTES:

- 1) Spindle cap to be made from Cast Iron to AS 1830.
- 2) Spindle cap to be polymeric coated to AS/NZS 4158.
- 3) Fix to valve shaft with M12 stainless steel set screw.
- 4) Dimple valve shaft at set screw location to aid fixing.

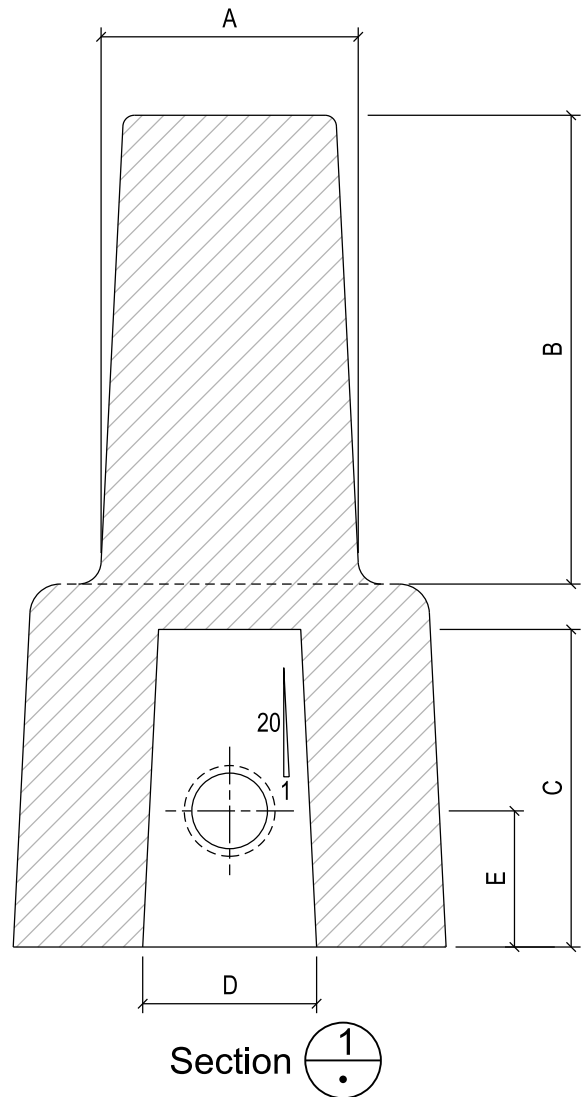

Section 1

SPINDLE CAP DIMENSIONS					
TYPE	A	B	C	D	E
Valve / 50, 80 & 100mm	34	62	42	23	18
Valve / 150, 200, 250 & 300mm	35	62	49	32.75	21

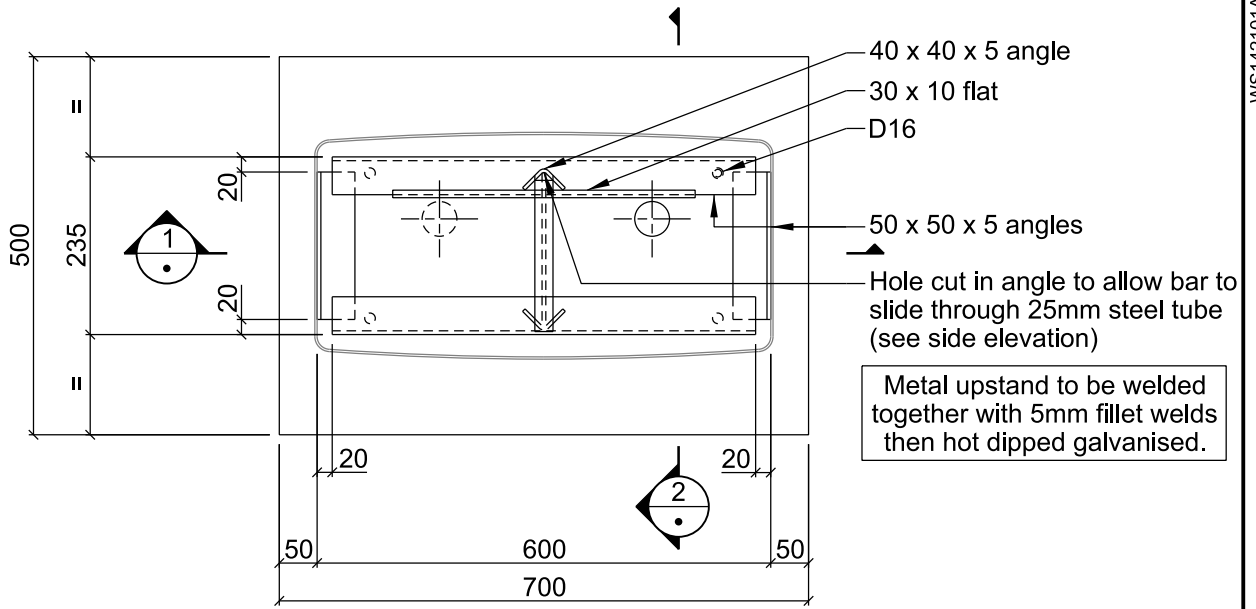

PLAN - UPSTAND ONLY

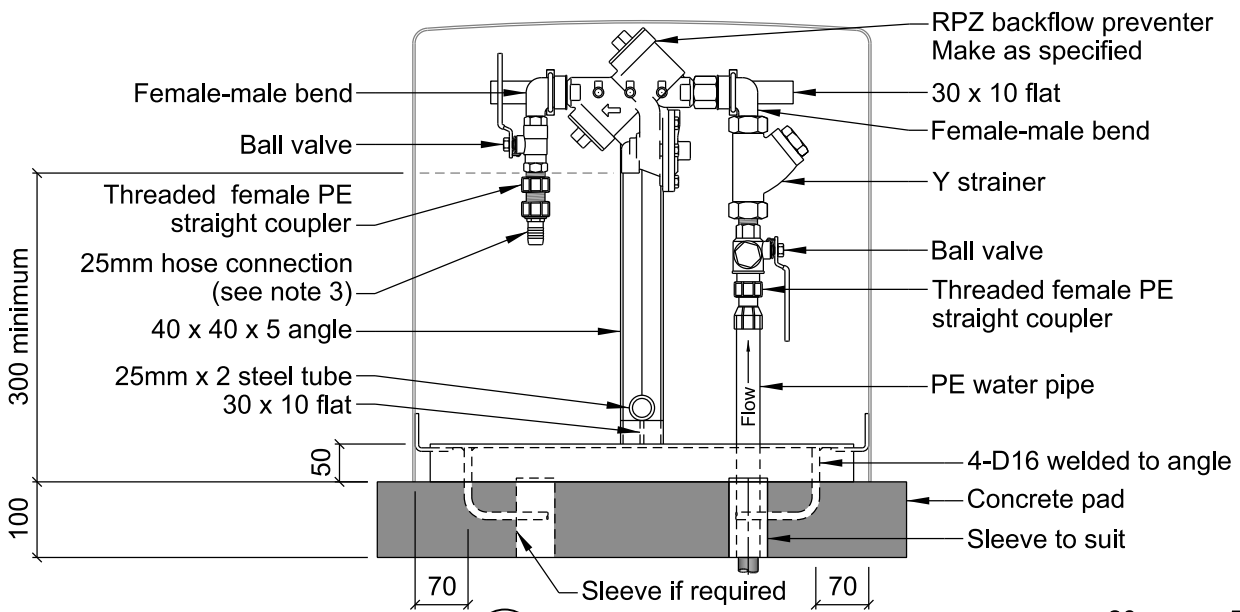

FRONT SECTION

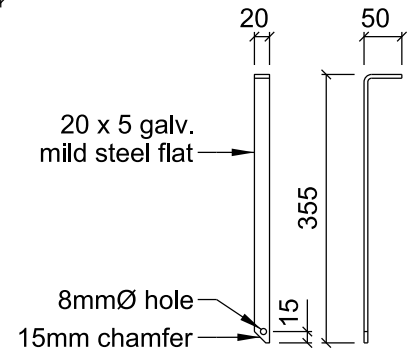

LOCKING BAR DETAIL

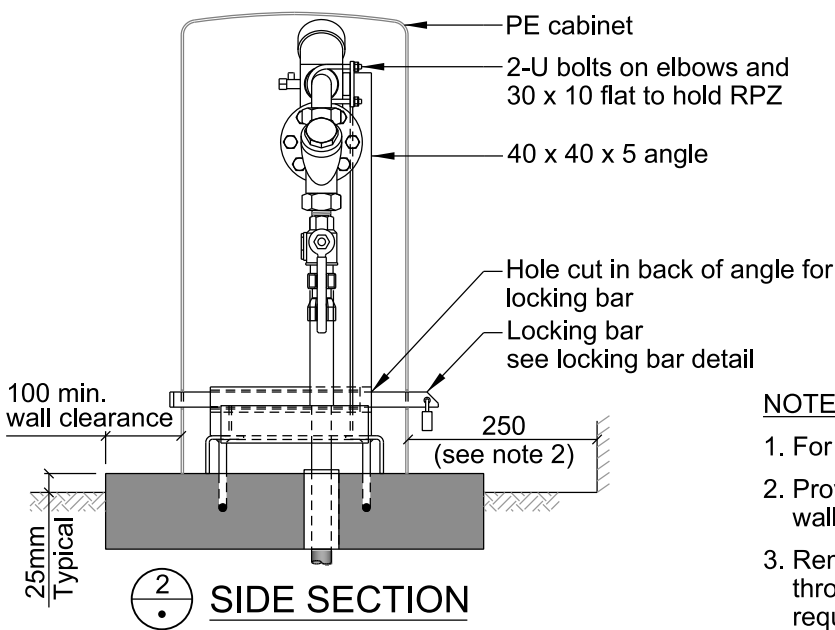

SIDE SECTION

NOTES:

1. For 15 or 20mm connections only.
2. Provide 250mm clearance to adjacent walls for locking bar / padlock access.
3. Remove connector. Extend water pipe through concrete pad where hose connection requires installation in a separate toby box.

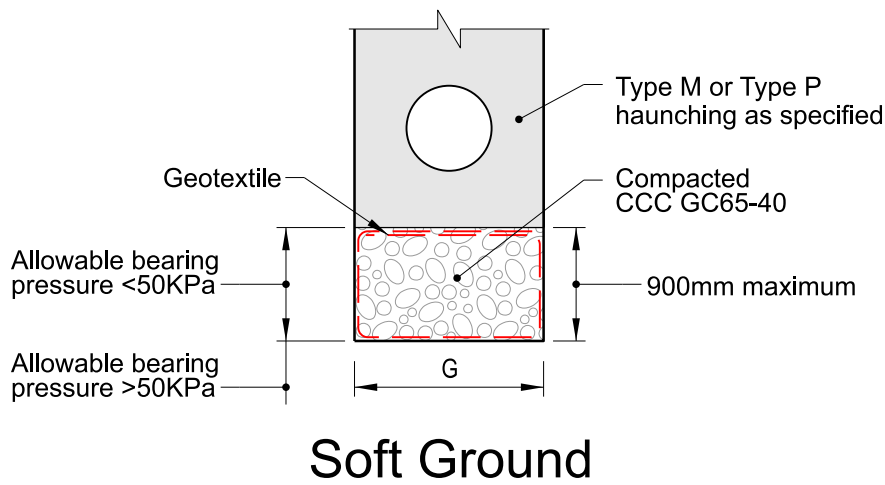

NOTES:

1. Where the depth to the base of the foundation may exceed 3.0m from the finished ground level, site specific design is required.
2. Geotextile installation shall be in accordance with TNZ F/7.